

ALL DESIGN, OPERATIVE AND PROCESS DATA PERTAINING TO THE ARTICLE SHOWN ON THIS SHEET IS THE PROPERTY OF POLYPHASER CORPORATION. THE INFORMATION IS NOT TO BE COPIED, REPRODUCED, REVEALED TO OR APPROPRIATED BY OTHERS WITHOUT THE EXPRESS WRITTEN CONSENT OF POLYPHASER CORPORATION.

REVISIONS					
REV	LTR	DATE	ENG	MKTG	Q.A.

MAXIMUM CHARACTERISTICS DATA (IX-H)

TURN-ON(@10mA):
 +9Vdc ±10%
 UL 497B STRIKE VOLTAGE BREAKDOWN
 (100 Vdc /SEC RISE):
 +8.4 TO +9.6 Vdc
 RESISTANCE:
 1Ω ±20%
 DATA RATE:
 UP TO 100Mbps
 MAX HOLDING CURRENT:
 400mA @ +20°C
 620mA @ -40°C
 290mA @ +50°C
 235mA @ +65°C

MAXIMUM CHARACTERISTICS (DC24)

TURN-ON (@10mA):
 ±33Vdc ±10%
 UL 497B STRIKE VOLTAGE BREAKDOWN
 (100 Vdc /SEC RISE):
 ±30.8 TO ±33.2 Vdc
 RESISTANCE:
 .05Ω ±20%
 CURRENT:
 2A MAX
 MAX HOLDING CURRENT:
 3.00A @ +20°C
 4.13A @ -40°C
 2.43A @ +50°C
 2.10A @ +65°C

GENERAL CHARACTERISTICS

SURGE:
 BELLCORE 1089 10/1000μs 100A
 TEMPERATURE:
 -40°C TO +65°C STORAGE/OPERATING
 WIRE RANGE:
 16 TO 28 AWG.
 CORD DIAMETER:
 0.114 TO 0.225 INCH W/ SMALL GROMMET
 0.250 TO 0.350 INCH W/ LARGE GROMMET
 APPLICATION:
 PANEL MOUNT.
 WEATHERIZED AFTER PROPER INSTALLATION OF
 GROMMETS AND TORQUING OF LID.
 ENVIRONMENTAL:
 MEETS BELLCORE #TA-NWT-000487 PROCEDURE 4.11,
 WIND DRIVEN RAIN (70MPH) RAIN INTRUSION TEST.

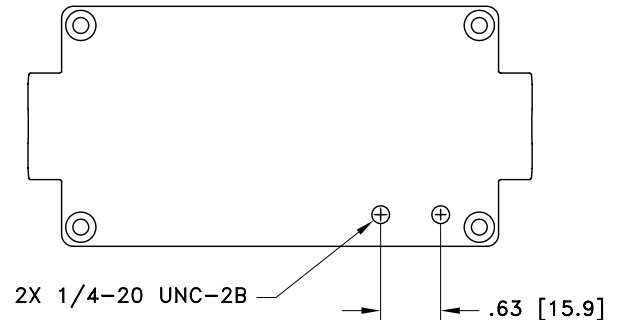
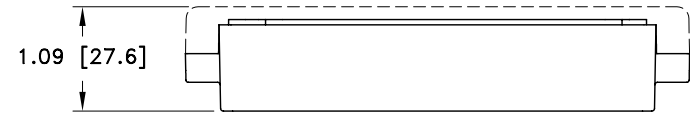
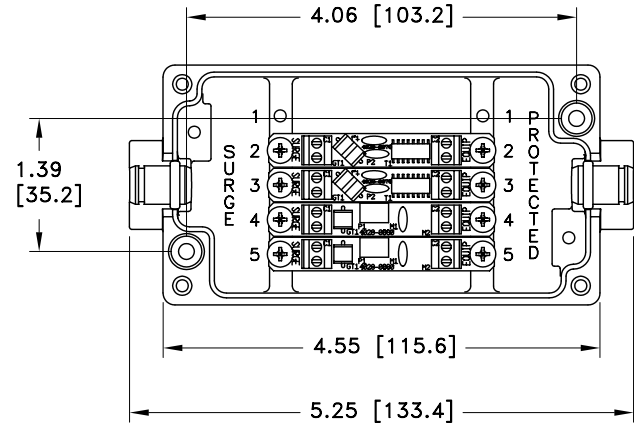
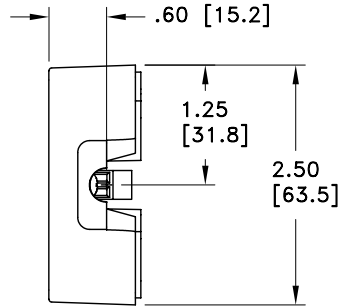

CUSTOMER APPROVAL: _____ DATE: _____

ALL DIMENSIONS SHOWN ABOVE ARE FOR REFERENCE ONLY.

NOTES:

- TORQUE 4X M4-20mm LID SCREWS TO 11lbf-in MINIMUM.
- ENSURE THAT ALL GROMMETS ARE PROPERLY SEATED FOR ENVIRONMENTAL SPECIFICATIONS.

DRAFTER S. HALL	DATE 08/25/06	 P.O. BOX 9000 MINDEN, NV 89423 TEL: 775-782-2511 FAX: 775-782-4476 DWG NO/PART NO/DESCRIPTION IX-2H2DC24 CUSTOMER PRINT	
MECH ENGINEER M. MATTSON	DATE 09/08/06		
ELEC ENGINEER L. CHANG	DATE 09/29/06		
MARKETING C. POCHECO	DATE 09/21/06		
QUALITY DEPT L. JACQUES	DATE 09/21/06		
CAGE CODE 61114	FILE NAME -C1	SCALE NOTED	SHEET 1 OF 1