

Passive Intermodulation Distortion in Connectors, Cable and Cable Assemblies

David Weinstein
Amphenol Corporation
Communication and Network Products
One Kennedy Avenue
Danbury, CT 06810

Introduction: Although not a new problem and well known to the satellite communications and microwave trunking industries, until the use of cellular phones became widespread, Passive Intermodulation Distortion (PIM) was of little concern to the connector designer. Until five years ago, most connector engineers had never heard of the phenomenon. Now, due to the frequency plans of today's modern base stations, the use of higher transmitter power levels and more sensitive receivers, PIM has surfaced as a potential problem for GSM, DCS, PCS and other wireless services.

In order to effectively design low PIM connectors and cable assemblies, an in-depth understanding of PIM is needed. This paper will discuss the causes, impact, and measurement of PIM. Guidelines to designing low PIM connectors and cable assemblies will be outlined including a discussion of the latest test procedures being developed by the international community. A look towards future requirements will also be discussed.

Definition: PIM is the unwanted signal or signals generated by the non-linear mixing of 2 or more frequencies in a

passive (or linear) device such as a connector or cable. Filtering can reduce or eliminate the PIM generated by the active devices in the system such as amplifiers, but components such as cable assemblies in the transmission line that cause PIM cannot be filtered. These passive coaxial components can be common to many if not all channels. The only way to reduce PIM in the transmission path is to design low PIM devices.

Concerns: If the circuit has non-linear characteristics, then the fundamental frequency components will become distorted in the time domain and generate a decaying series of higher order harmonic frequency components in the frequency domain. If these generated harmonic frequency components fall within the receive band and are of sufficient magnitude, they can effectively block a channel by making the base station receiver think that a carrier is present when one is not. Generally, the components of concern are 3rd, 5th and 7th order where the third order is of greatest signal strength, and therefore, of primary concern. If the fundamental frequencies are f_1 and f_2 , then the possible intermodulation frequency components can be described by Equation (1), where the sum of m and n is the product order.

$$f_{IM} = ? mf_1 + ? nf_2 \quad (1)$$

For example, $(2f_1 - f_2)$, where $m = 2$ and $n = 1$ is a 3rd order intermodulation product. Figure 1 shows the Global System for Mobile Communications (GSM) network band plan in order to illustrate the actual risk of interference

arising from the generation of IM products. If $f_1 = 930$ Mhz and $f_2 = 955$ Mhz, then $f_{IM} = 905$ Mhz, which falls within the uplink (receive) band.

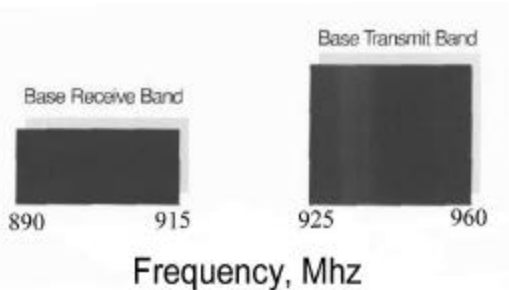

Figure 1. GSM Band Plan

Simplex systems, where a single antenna is used for both transmit and receive are naturally the most susceptible to PIM, however, they are the most economical. Duplex antenna systems help reduce the risk and cross polarization of the transmit/receive antennas increases the isolation even further, but costs naturally increase.

Causes: As stated earlier, in the general sense, non-linear mixing causes the generation of PIM. Specifically, there are 3 major causes of PIM in passive devices:

1. Poor contact junctions
2. Components made with, or plated with materials that exhibit some level of hysteresis
3. Contamination

Contact nonlinearities occur when a current carrying contact zone becomes separated. This usually occurs on a microscopic level and can be due to insufficient contact pressure, irregular contact surfaces, oxidation causing a metal/oxide junction, contact impurities or corrosion. This small separation of

contact surfaces can generate a voltage potential barrier, where electron tunneling (known as the diode effect) or microscopic arcing may take place resulting in a nonlinear voltage to current ratio.

The use of ferromagnetic materials such as nickel or steel within the current path, especially at high power levels, can also generate PIM due to the nonlinear voltage to current ratio and hysteresis effect of these materials.

Contaminants such as metal particles from machining operations that touch current carrying surfaces can also cause intermittent nonlinearities, generating PIM.

Specifying PIM: PIM is normally specified in terms of dBm or dBc. dBm is a measure of power relative to 1 milliwatt. Zero dBm is 1 milliwatt into a 50 ohm load. dBc is a measure of dB below a specified carrier level. For example, 20 watts, or 43 dBm is a typical input power level specified for testing passive devices. A normal test requirement for allowable PIM might be -110 dBm. This would make the specification $-110-43$, or -153 dBc. The typical range seen today is -100 dBm to -120 dBm with two $+43$ dBm carriers.

Measuring PIM: Acceptable levels of PIM are extremely low and therefore difficult to measure accurately. As compared to S parameters, PIM cannot be simulated or predicted using HFSS or other analytical software. The only way to determine if a device generates

PIM, and to what level, is to measure it. Even testing to AQL levels is dangerous because PIM is very unpredictable and can be generated in what appear to be perfectly designed and constructed devices. 100% testing is suggested.

The International Electrotechnical Commission, Technical Committee 46, Working Group 6 has developed a generic test procedure for measuring PIM. See Figure 2.

Two methods are described: Reflected and Transmitted.

The two different frequencies are amplified, then filtered and combined in a diplexer. The composite signal is applied to the device under test (DUT) through a diplexer. For the reflected mode, a one port device or terminated 2 port device is placed on the output of the diplexer and the PIM that is generated is filtered in the diplexer and detected by the receiver. In the transmitted mode, the 2 port DUT output is connected to a second diplexer.

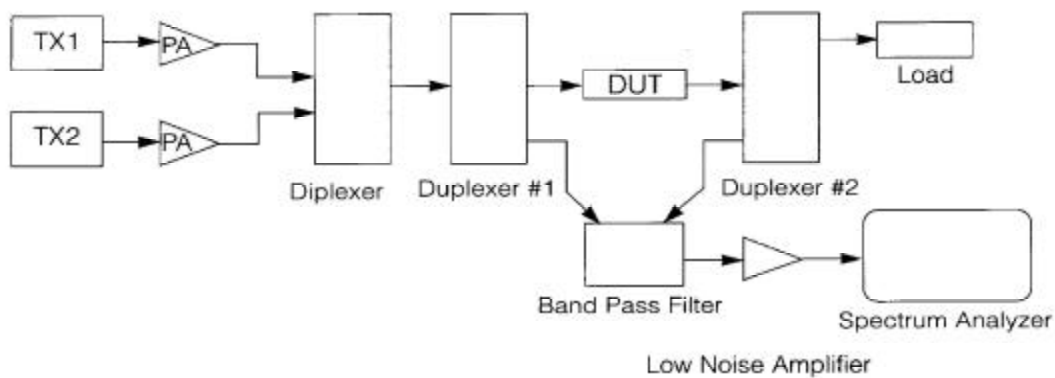

Figure 2. IEC Test Set-up [1]

For electrically short devices such as adapters, there will be no measurable difference in PIM as a function of frequency whether tested in the reflected or transmitted mode. However, as the device becomes electrically long, such as for cable assemblies, the PIM signal at Port 1 in the reflected mode is a combination of the Port 1 response and the phase shifted response from the IM sources at Port 2. In the transmitted mode, the

PIM signals always arrive in phase at port 2 in the transmitted mode. Therefore, transmitted measurements can be made at a fixed pair of frequencies. See Figure 3. In practice, "system" cables are generally used to prevent damage to test port connectors resulting in more complex models. This effectively eliminates the fixed frequency measurement as an option since the model is only correct for this one specific configuration.

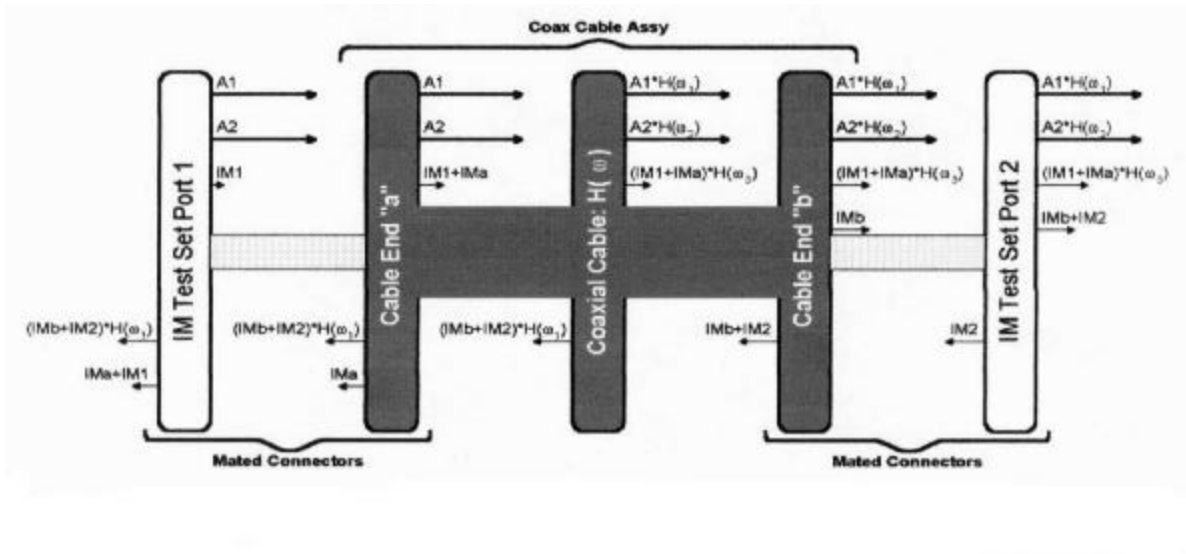

Figure 3. Cable Assembly PIM Model [2]

Further investigation has also shown that when testing well matched, low loss devices such as cable assemblies and adapters, harmonics of the input signals can be transmitted through to the second duplexer. Since the duplexer is not well matched at harmonic frequencies, the signals can reflect back into the DUT. This can generate additional PIM where with other orders may contribute to false

readings. Filtering can help, but as stated earlier, swept, reflected measurements are recommended.

Sweeping can be accomplished in several manners. Several pairs of transmit frequencies can be chosen to give equal steps through the receive band. Another common method used is to fix one of the transmit frequencies, (f1) at the bottom of the band and

sweep the other frequency, (f_2) down. Then reverse the operation by fixing f_2 at the top of the band and sweeping f_1 up.

It is essential that a low IM load be used when testing 2 port devices. With currently available test equipment, the spectrum analyzer or receiver noise floor should be approximately -140 dBm. System residual PIM of the test set components should be between -125 and -135 dBm. A poor load will make it impossible to measure low PIM devices. The most common type of load is a cable load consisting of semi-rigid cable soldered to a high quality connector. Typically, cable generates extremely low PIM, and careful connector design, as will be discussed later, can result in a termination that generates PIM at levels less than -125 dBm.

Commercial turnkey systems can be purchased for the different frequency bands. See Figure 4. In addition, test systems can be built using individual components as described in the IEC test procedure. See Figure 5.



Figure 4. Commercial Turnkey System [3]

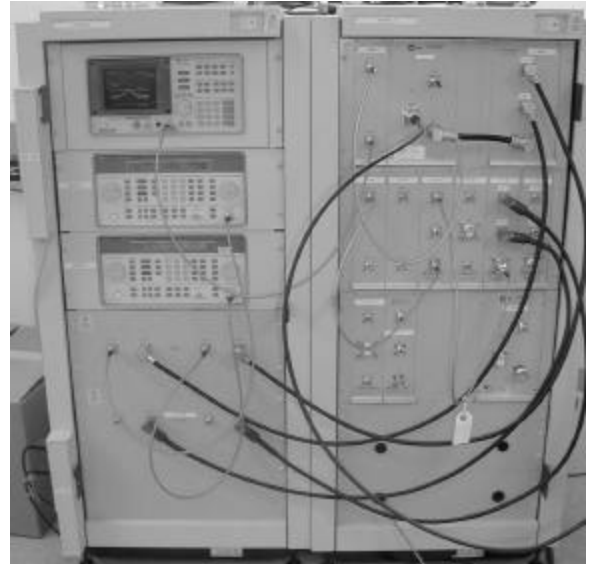

Figure 5. System built using discrete components

Minimizing PIM in Practice: There are six facets of connector design that must be evaluated when considering low PIM design. They are: contact design, connector mating interface, connector internal junctions, cable attachment, materials and plating.

Contact design: Contact design and construction is one of the most important, yet often overlooked aspects in suppressing PIM generation. Contact junctions must be designed to provide high contact pressures at the point of desired current flow. The joints must be capable of performing over the life of the system especially during dynamic flexing and vibrations.

There are typically five different types of contact junction designs used in joining two conductors together. These include solder, butt contact, spring fingers, clamp and crimp. The connector itself can be divided into three general regions in order to identify

the region of contact junctions. These include the connector mating face, connector internal junctions, and the connector to cable attachment.

Connector Mating Interface: The two most common interfaces used for low PIM applications are the Type N and DIN 7/16. The Type N is very popular in North America and is used commonly among radio manufacturers, while the DIN 7/16 (DIN standing for Deutsche Industrie Normen) originated in Europe and has become very popular on digital cellular systems due to its low PIM and high power handling capabilities. The 7/16 interface is very robust and provides a large contact surface area and mating force resulting in low contact resistance. Although not in common usage, TNC and even SMA have seen some usage in low power or receiver applications.

Connector Internal Junctions: A common axiom states that more is better. When designing low PIM connectors, less is better, at least when it comes to internal junctions. One-piece center contacts or solder joints, if one-piece designs are impractical, are best. One-piece bodies are also desirable. Threads and press-fit configurations can lead to problems.

Cable Attachment: Mechanical stability of the cable/connector junction is of utmost importance. Small movements caused by flexing can be translated into significant PIM. Center conductors should be soldered, not crimped. Braided cables are especially susceptible to PIM. The cable of choice by far is a copper jacketed cable that is either seamless, such as semi-rigid

types, or welded, corrugated annular and helical styles. Once again, soldering the outer conductor is the method most likely to prevail in the long run. Cables with a diameter of 1/2" and larger are fairly rigid and flex less than smaller diameter cables. Therefore in applications using large diameter cables, mechanical clamping to the outer conductor may be tolerated.

Materials: Ferromagnetic materials such as nickel or steel must be eliminated from the current path due to their non-linear characteristics. Brass and copper alloys are generally accepted as linear materials. Tests have shown that nickel plate under gold on the center contact will typically result in a 40 to 50 dB increase in PIM. Stainless Steel in the body will usually give a 10-20 dB increase in PIM.

Plating: Connector components are plated for electrical and environmental purposes. Silver or white bronze is used for its high conductivity in order to significantly reduce contact junction resistance. Gold does not oxidize in air and this makes it popular for use in spring contact junctions where high contact pressures are not attainable. Typically, Type N and Din 7/16 will have silver plated contacts. Due to the skin effect, the RF current densities only reside within a few skin depths at the surface of the conductor. It is therefore important to ensure sufficient plating thickness such that the majority of the current travels within the plating material. Approximately 98% of the current density travels within 4.6 skin depths. At 1 Ghz, on a silver plated surface, the skin depth is .002mm or 78 uin [4].

Cleanliness: Extreme care (and this cannot be overemphasized) must be taken to ensure no metal particles or chips of any kind from the assembly process end up inside the assembly. This relates to both assembly of the connector, trimming of the cable and soldering operations. Excess flux will attract other contaminants. Pieces of copper jacket or braid will compromise the performance and cause intermittent operation.

Cable Considerations: The connector, is considered the most likely suspect when troubleshooting problem cable assemblies. Well made cable will generate extremely low levels of PIM, but poorly made cable can, and will cause problems. One area of concern is the weld along the seam in annular and corrugated cables. Another area of concern is the adhesion of the copper to the center conductor. Copper clad aluminum is a common center conductor material. Poor clean room and assembly practices can lead to copper flaking off the aluminum and generating significant PIM.

Other Influences: Mechanical, environmental and electrical factors can influence the performance of the device. PIM can be generated in an otherwise statically, well performing cable assembly. It is not uncommon to put an assembly on a PIM test set up and see excellent results in a static condition. In the field, any mechanical flexing due to wind and vibration can have a devastating impact. In order to test for this before the assembly is installed, dynamic PIM tests are being developed by the IEC. Raw cable and final cable assemblies will be subjected

to flexing and rotational movement using a fixture as shown in Figure 6.

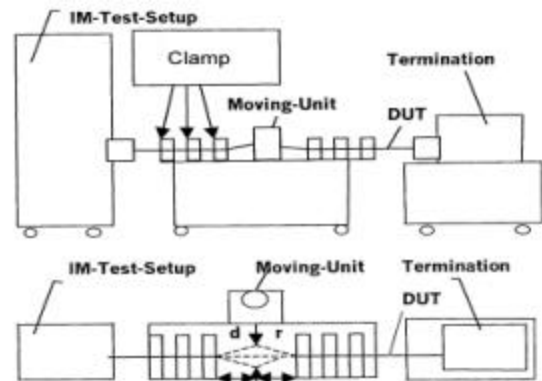

Figure 6. Cable Flexing Fixture [1]

Connectors will be assembled on very short cable assemblies and subjected to an impact test from a free falling weight as shown in Figure 7. Temperature cycling and thermal shock can also have a significant effect on PIM and will likely be included in individual customer specifications.

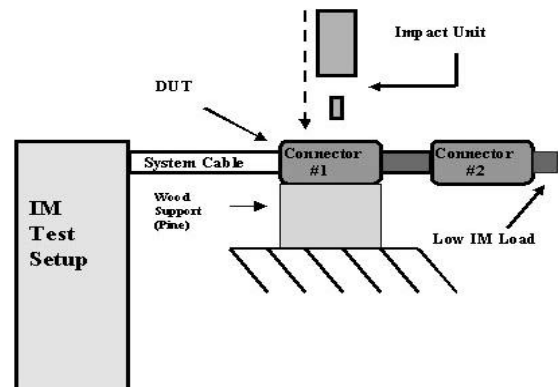

Figure 7. Connector Test Set-up [1]

Questions have arisen as to the effect of impedance or VSWR on PIM. Experiments have been performed and data presented to show that VSWR has little or no influence on PIM. See Figure 8.

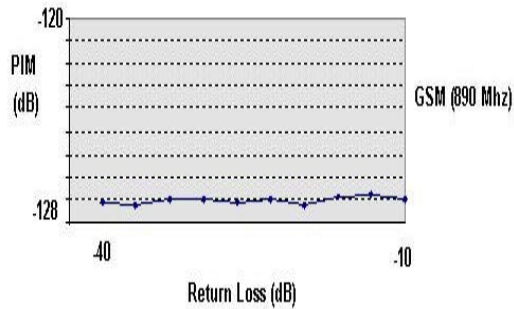

Figure 8. PIM vs. Return Loss

Sometimes, it is desired to be able to predict the performance of a device at a higher power level than available. High power amplifiers are expensive and difficult to obtain. The device can be tested at a lower power level and the performance at a higher power level can be approximated. In simple broadband devices terminated into a broadband termination, one would expect the PIM to change by 3 dB for every one dB change in input power. Experimentation (See Figure 9) has shown that this relationship is not always as expected but 3 is reasonable. Some of the possible reasons are:

1. High VSWR at harmonic frequencies (ie. $n \cdot f_1$ or $m \cdot f_2$)
2. Non linear behavior of electromechanical junctions as they approach a breakdown potential
3. Coefficients of higher order than 3 that occur at the frequency of the third order [3,7]

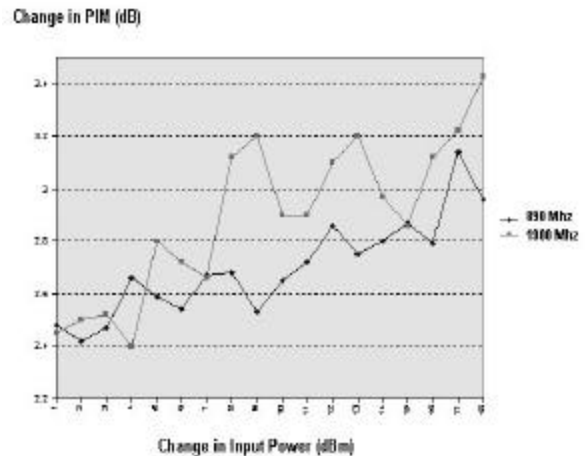

Figure 9. PIM vs. Input Power Level

In general, for connectors and cable assemblies, PIM is not frequency dependent. However, there has been some discussion that testing a cable at different frequencies might yield different results due to the skin depth. For example, the current density at 1800 Mhz would be twice as high as at 900 Mhz. No experimentation to date has shown consistent differences due to frequency effects. Assuming the insertion loss of the cable does not change appreciably and the sources of PIM do not vary dramatically with frequency, it is likely that the PIM measured at 900 Mhz will be similar to that measured at 1800 Mhz.

PIM can be time dependent in that the RF heating effect will vary the mechanical junctions inside the assembly. In such cases, depending on the design and assembly condition of the device, the PIM can either increase or even decrease over time. Well designed and properly made components should not vary with time.

The Future: It is a certainty that the airwaves will become more crowded. Additional methods will have to be developed to accommodate the proliferation of signals. Two tone PIM testing will likely give way to multi tone tests which are more reflective of real world conditions. Currently, multi tone testing is extremely expensive and rarely performed. Additional orders of PIM, and therefore more sensitive test systems will also be needed. As more services compete for space, testing for 2nd, 5th, 7th, 9th and higher orders of PIM become essential. High power testing at the level of +48 dBm is being discussed. The future of PIM testing will present numerous challenges.

Biography: David Weinstein received his BSEE from the City College of New York in 1975. Over the past 32 years, he has held various laboratory, engineering and management positions with several connector companies. He currently has 4 patents and several publications relating to connectors. Since 1997 he has been the Principal RF Engineer with Amphenol Corporation, Communications and Network Products Division, specializing in Passive Intermodulation distortion and the RF analysis of connectors and other devices using HFSS software.

References:

1. RF Connectors, connector cable assemblies and cables- Intermodulation level measurement IEC 62047
2. Deats and Hartman, Measuring the Passive –IM Performance of RF Cable Assemblies, Microwaves and RF, March 1997
3. <http://www.summitekinstruments.com/>
4. Theodore Moreno, Microwave Transmission Design Data , Dover Publications, 1948
5. Amphenol Signals, Issue No. 2, February 1997
6. Amphenol Signals, Issue No. 3, August 1997
7. Hartmut Gohdes, Impact of Power Variation on 3rd Order Passive Intermodulation of Coaxial RF- Cables and Their Connectors, International Wire and Cable Symposium Proceedings, 1997